



ESCORTS

RAILWAY EQUIPMENT DIVISION



Transformation through
Engineering and Innovation

SUSPENSION SYSTEMS



HYDRAULIC DAMPERS

ESCORTS LIMITED is manufacturing heavy duty Hydraulic dampers for Indian railways since 1962. Escorts is the primary supplier of Hydraulic dampers to the Indian Railways which is one of the most critical components. Escorts has supplied dampers to various international railways such as Egypt, Sri Lanka, Taiwan, Philippines, UK, Tanzania, Iran, Myanmar, and many more.

More than 10,00,000 dampers were supplied for various applications across the globe.

Application

- Locomotives
- Passenger Mainline Coaches
- LHB Coaches
- EMU Coaches
- Special Vehicles -Overhead Cranes, Accident Relief Cranes, Track Levelling Vehicles, OHE Car, etc.

AIR SUSPENSION CONTROL EQUIPMENT

ESCORTS LIMITED manufactures Air Suspension Control Equipment for Indian railways. The equipment ensures a constant floor height on coaches by optimizing the values of stiffness and damping the vibration to provide passenger comfort.

This equipment is used to control the secondary stage of air suspension.

Application

- EMU/DMU
- LHB Coaches

FAILURE INDICATION AND BRAKE APPLICATION (FIBA) FOR LHB COACHES

ESCORTS LIMITED also manufactures FIBA for Indian Railways. To meet the requirement of a fool proof arrangement in the air suspension design, FIBA is connected with each air spring fitted under the coach.

The basic principle in this arrangement is to actuate the application of brakes in the event of air spring failure, which will immediately reduce the speed of the train and ultimately bring the train to a standstill.

Application

- High Speed LHB Coach
- EMU

HYDRAULIC DAMPERS

PRODUCT RANGE

- Primary Vertical Damper
- Secondary Vertical Damper
- Secondary Lateral Damper
- YAW Damper

APPLICATION

- Locomotives
- Passenger Mainline Coaches
- LHB Coaches
- EMU Coaches
- Special Vehicles -Overhead Cranes, Accident Relief Cranes, Track Levelling Vehicles, OHE Car, etc.

TECHNICAL CHARACTERISTICS

Types of End Mountings

- Rubber disc
- Rubber flange type mountings
- Spherical block/silent block type mountings
- Articulated bearing type mountings
- Bonded/Non bonded rubber sleeves with Steel bush mountings

Damping Force Range

- 100 Kgf- 2500 kgf at up to 0.6 m/s velocity max.
- Low speed (0.01 m/s min) and high Force (upto 2000 kgf) for YAW damper type applications.
- Multi speed characteristics

Family Sizes

- Max. Extended length 1100 mm
- Min. Compressed length 200 mm

SPECIAL FEATURES

Custom Design

Escorts Hydraulic dampers are custom designed for various unique rail applications, with respect to damping force characteristics, end mountings family of sizes etc.

DURABILITY

Escorts Hydraulic dampers give extended intervals of overhaul, hence lower maintenance cost

MANUFACTURING AND TESTING FACILITY

- Servo Hydraulic Performance cum Endurance Testing Machine
- Damper Strength Testing Machine

RECONDITIONABLE

Designed for easy and trouble free maintenance and can be reconditioned on site. Escorts has assisted many railways in setting up reconditioning shops.

Escorts also supplies complete kits for reconditioning of Hydraulic Dampers including Testing Equipment, Tooling and Fixtures required for reconditioning.



AIR SPRING CONTROL EQUIPMENT

Air spring control equipment ensures a constant floor height on coaches by optimizing the values of stiffness and damping the vibration to provide passenger comfort. This equipment is used to control the secondary stage of air suspension.

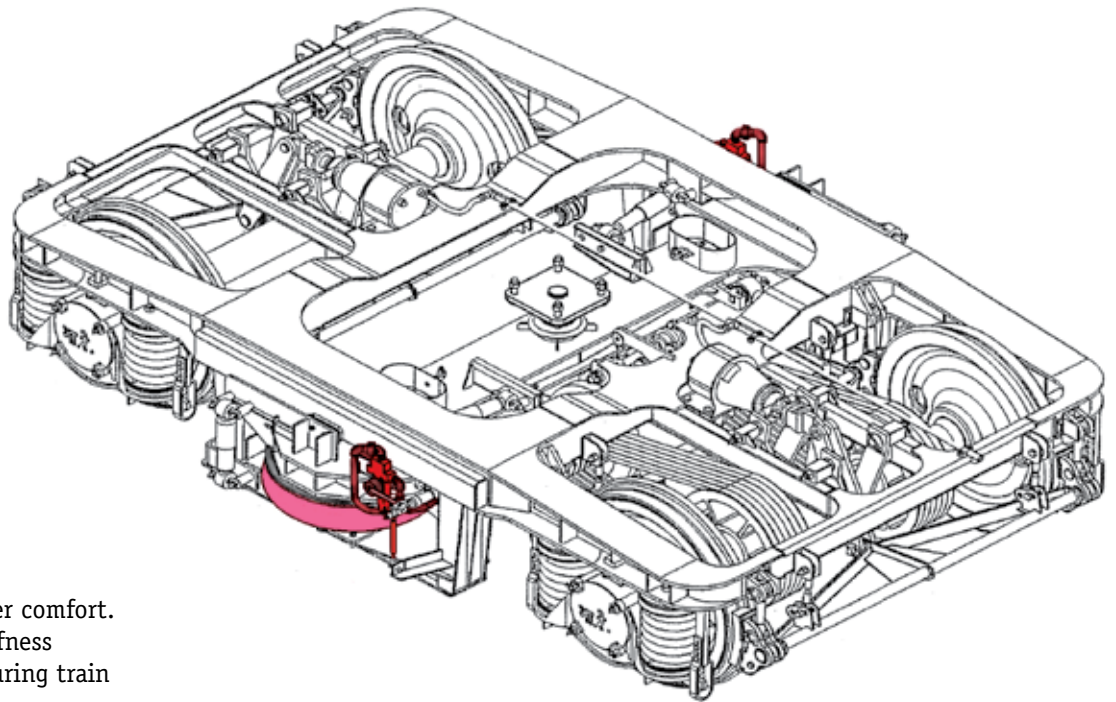

APPLICATION

- EMU/DMU
- LHB Coaches

SALIENT FEATURES

- Provides more passenger comfort.
- Optimized value of stiffness
- Damps the vibration during train movement
- Maintains gap between frame and bogie bolster
- Maintains constant floor height of the coaches



LEVELING VALVE



INSTALLATION LEVER



DUPLEX CHECK VALVE



CDC



RESERVOIR

FAILURE INDICATION AND BRAKE APPLICATION (FIBA) FOR LHB ALSTOM AND EMU COACHES

To meet the requirement of a fool proof arrangement in the air suspension design, FIBA is connected with each air spring fitted under the coach.

The basic principle in this arrangement is to actuate the application of brakes in the event of air spring failure, which will immediately reduce the speed of the train and ultimately bring the train to a standstill.

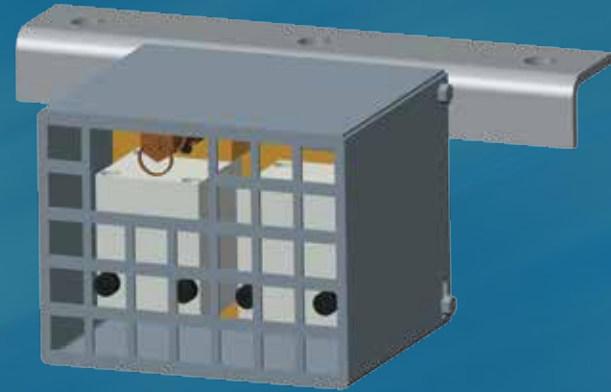

SALIENT FEATURES

- Aluminium body
- Good performance
- Easy Maintenance
- Environment Friendly

APPLICATION

- High Speed LHB Alstom Coach
- EMU
- Passenger Coach with air spring

ADVANTAGES OF FIBA

- The valve is smaller in size and economical
- The valve is machined from aluminium block and light weight
- Easy to handle due to its smaller size and light weight
- Compact in size with less no. of parts
- More reliable and less maintenance





ESCORTS

RAILWAY EQUIPMENT DIVISION

Head Office & Works:

Plot No. 115, Sector 24,
Faridabad - 121 005
Haryana, (India)
Email: rail@escorts.co.in
Web: escortsrailwayproducts.com
Tel.: 91-129-2516382, 6608
Fax: 91-129-2232148

Mumbai Branch:

Times Square, Unit No. A-1,
A-Wing, 3rd floor,
Andheri Kurla Road,
Andheri East
Sakinaka, Mumbai - 400 059
Maharashtra, India
Email: mumbai@escorts.co.in
Tel.: +91-22-24218159
Fax: +91-22-24218153

Chennai Branch:

M-3, "M" Block, 3rd Avenue,
Anna Nagar East,
Chennai - 600 102
Tamil Nadu, India
Email: chennai@escorts.co.in
Tel.: +91-44-26287229
Fax: +91-44-26287341

Kolkata Branch:

South Western Wing,
9th Floor, "AC Market",
1, Shakespeare Sarani,
Kolkata - 700 071
West Bengal, India
Email: kolkata@escorts.co.in
Tel.: +91-33-22825191
Fax: +91-33-22814518